

Visit www.timbertech.com/installation to view TimberTech installation videos.
Consult your local building codes for guard and handrail requirements.



IMPORTANT INFORMATION

- Please read all instructions completely before starting any part of the installation. Always make sure to visit www.TimberTech.com to ensure you are viewing the most current installation instructions, care and cleaning, technical information and more.
- TimberTech Railing should be installed using the same good building principles used to install wood or composite railing and in accordance with the local building codes and the installation guidelines included below.
- AZEK Building Products LLC and its affiliates accepts no liability or responsibility for the improper installation of this product.
- TimberTech Railing may not be suitable for every application and it is the sole responsibility of the installer to be sure that the Railing is fit for the intended use. Since all installations are unique, it is also the installer's responsibility to determine specific requirements in regards to each Rail application.
- TimberTech Railing recommends that all applications be reviewed by a licensed architect, engineer, or local building official before installation. If you have any questions or need further assistance, please call AZEK Customer Service at 877-ASK-AZEK (877-275-2935), or visit our website at www.TimberTech.com.
- TimberTech Railing is tested as a whole system and should be used that way. It is not intended to be used in conjunction with other railing systems or fasteners.
- The following Installation Guidelines are applicable only for installation of Reliance Rail - Core Series.
- **IMPORTANT:** Make sure the DRIVE TOOL/DRILL is configured or set to use the SCREW setting when driving and/or tightening all FASTENERS. It is very Important not to overdrive fasteners. The use of impact type drill drivers can increase the risk of overdriving fasteners.
- **SAFETY:** Always wear goggles when handling, cutting, drilling, and fastening materials.
- Failure to install this product in accordance with applicable building codes and TimberTech's written Reliance Rail - Core Series Install Guide may lead to personal injury, affect rail system performance, and void the product warranty.
- The buildup or generation of static electricity is a naturally occurring phenomenon in many plastic based products such as carpeting, upholstery, and clothing, and can occur on alternative decking under certain environmental conditions. This static electricity can discharge once contact is made with hardware, railing, or other conductors of electricity.

Parts Overview

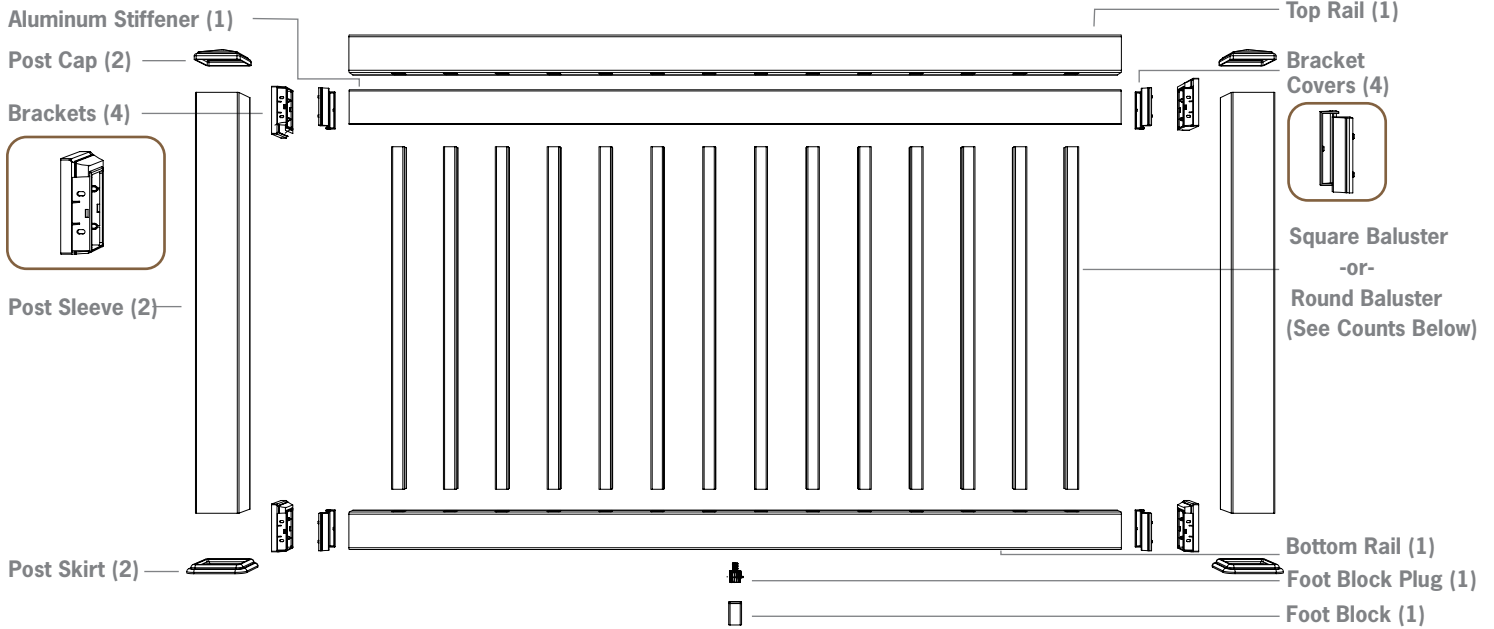

Component Dimensions

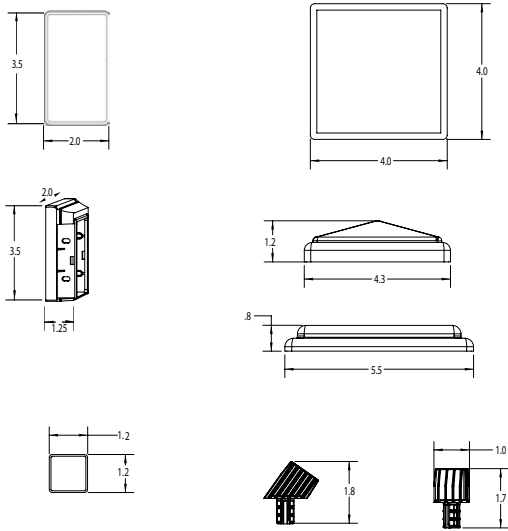

Components Needed For Installing One Reliance Rail Core Section

Components available in Level and Stair Rail Kits	Level Rail Kit	Stair Rail Kit
	1 - Top Rail 1 - Bottom Rail 1 - Aluminum Stiffeners 1 - Hardware Mounting Kit Square Balusters 14 - 6' Rail 19 - 8' Rail Round Balusters 15 - 6' Rail 20 - 8' Rail	1 - Top Rail 1 - Bottom Rail 1 - Aluminum Stiffeners 1 - Stair Hardware Mounting Kit Square Baluster 12 - 6' Rail 16 - 8' Rail Round Balusters 12 - 6' Rail 16 - 8' Rail
Additional Components Needed for Each System (Sold Separately)	2 - Post Sleeves 2 - Post Caps 2 - Post Skirts	39" Post Sleeve and 54" Post Sleeve come in a kit with flat cap and skirt

OPTIONAL 45° ADAPTER

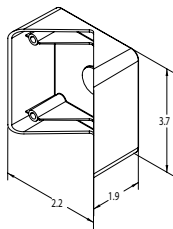

Tools Required

- Miter Saw (12" 80- to 100-tooth fine-finish blade)
- Drill
- Drill Bits: 1/2" & 5/32"
- Tape Measure
- Safety Glasses
- Level
- Speed Square
- T25 Driver Bit
- 6" Drill Bit Extension

Visit www.timbertech.com/installation to view TimberTech installation videos. Consult your local building codes for guard and handrail requirements.



IMPORTANT NOTE:

- Prior to construction, check with your local regulatory agency for special code requirements in your area.
- Common railing height is 36" or 42".
- TimberTech Reliance Rail - Core Series 8' and 6' Rails are designed not to exceed 8' and 6' from inside of post to inside of post, using 4" posts, respectively.
- For all other applications, consult a design professional or a TimberTech Railing representative for more information.
- Posts must be installed plumb and level with each other. This is specifically critical for Over-the-Post applications.
- Read instructions completely to get an understanding of how the product goes together and how each piece affects the other.
- Not compatible with Glass Infill Panels.
- 4x4 lumber posts or TimberTech Secure Mount Posts should be installed plumb.
- Cut slowly, using a fine tooth saw blade to avoid chipping.

Reliance Rail™ Core Series is available in 6' or 8' lengths.

Identifying Post Locations and Railing Section Lengths

When designing and laying out your railing project, you must take the following into consideration:

- Measurements are from inside of post to inside of post as noted in "Important Note" above. Rails are produced to 96" and 72", although it is common to trim down rail lengths to fit within 96" or 72" from center-of-post to center-of-post measurement. Maximum finished rail length must not exceed 96" for 8 ft and 72" for 6 ft from inside of post to inside of post. Please allow for finished end cuts and angles when selecting rail length.
- Determine how many 6' or 8' Core Rail sections you need and check to be sure you have all the components (and quantities) listed in the chart on page 2.

1

INSTALL POST SLEEVES AND POST SKIRTS

- Ensure posts are level and plumb.
- Trim Post Sleeves to desired length if necessary.
- Slide Post Skirt over Post Sleeve. Slide Post Sleeve over the post (do not force). For best fit, shim Post Sleeve between sleeve and support post.

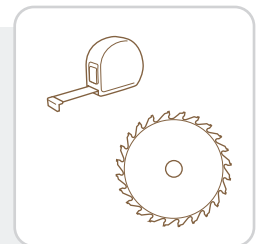
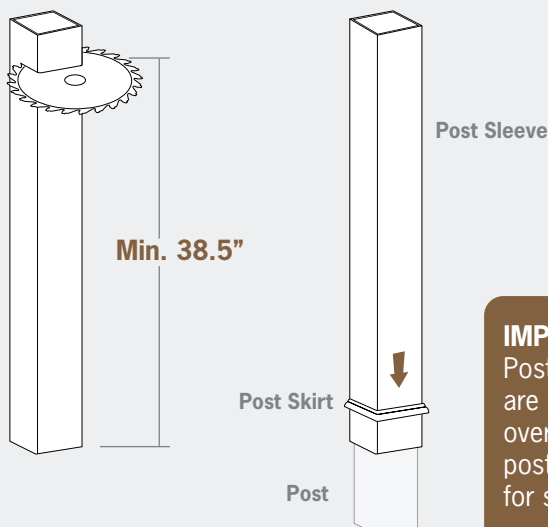

IMPORTANT: Be sure to install Post Skirts before railing sections are installed. Installing Post Skirt over the post prior to sliding on post sleeve can reduce potential for scratches.



2

CUT TOP AND BOTTOM RAIL

- If necessary, cut rails to desired length to ensure proper fit between posts. Ensure spacing between balusters or between baluster and post is centered and does not exceed 4".
- Ensure the Aluminum Stiffener is in the Top Rail as shown below with long leg of P-shape pointing towards routed holes. Cut the Top Rail with the Aluminum Stiffener inside at the same time.

Determine whether the rail will be cut with a hole or baluster in the center. Note: the maximum distance between balusters or between last baluster and post should not exceed 4".

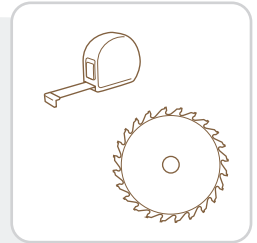

Round Balusters

Note: round baluster rails are designed for center-to-center and must be cut down to ensure 4" maximum gap between last baluster and post, or additional balusters must be added if a full 72" or 96" inside of post to inside of post length is desired.

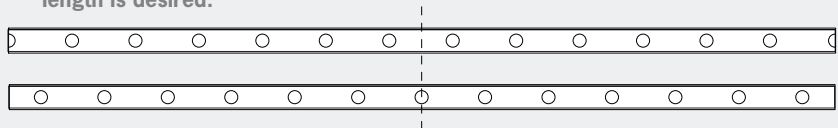

Square Balusters

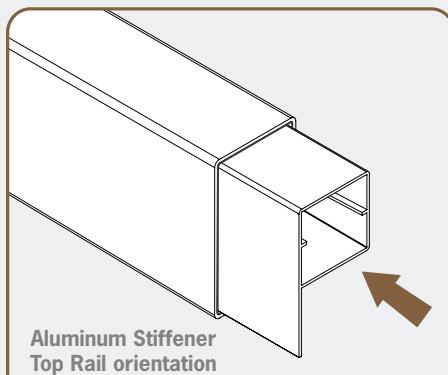
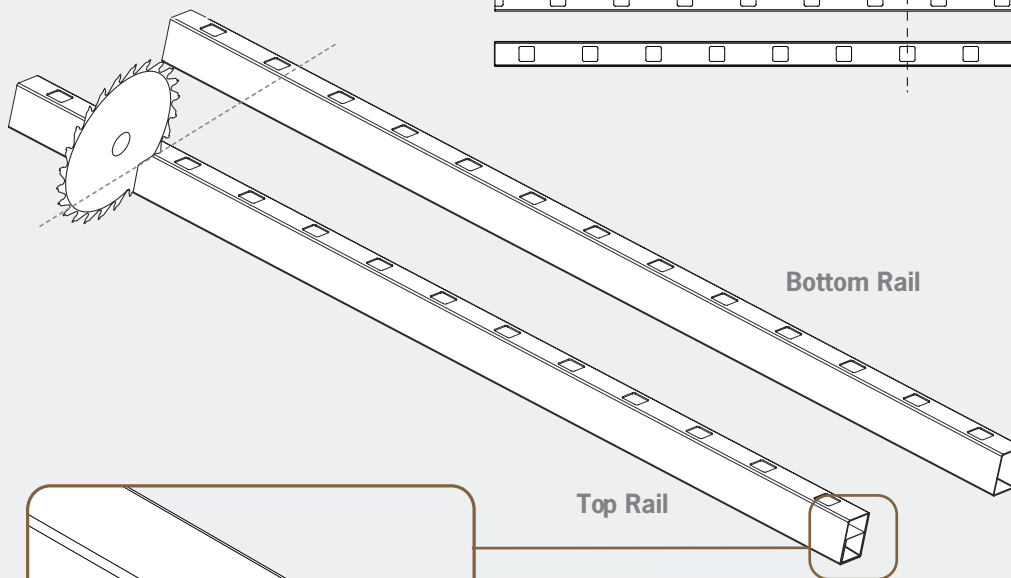
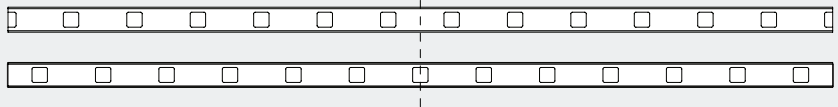

Aluminum Stiffener
Top Rail orientation

Note: Be sure the Aluminum Stiffener is flush with the ends of the top rail when cutting, and the long leg of the P-shape points towards the routed holes

Top Rail

Installation Tips: Ensure proper spacing between first or last baluster and post. Minimum spacing should be at least 1.5" to provide room for bracket. Rail may be cut 1/8"-1/4" short of span to allow for expansion and avoid scratching upon install

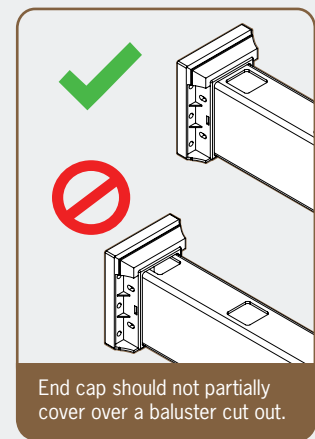

End cap should not partially cover over a baluster cut out.



Make sure the Top and Bottom Rail are cut to the exact same length and baluster holes align.

3

ATTACH FOOT BLOCK TO THE BOTTOM RAIL

- Measure and drill a 1/2" hole into the bottom of the Bottom Rail. (See below for location)
- Cut Foot Block to 2".
- Press fit Foot Block Plug into 1/2" hole.
- Press fit Foot Block onto Foot Block Plug.

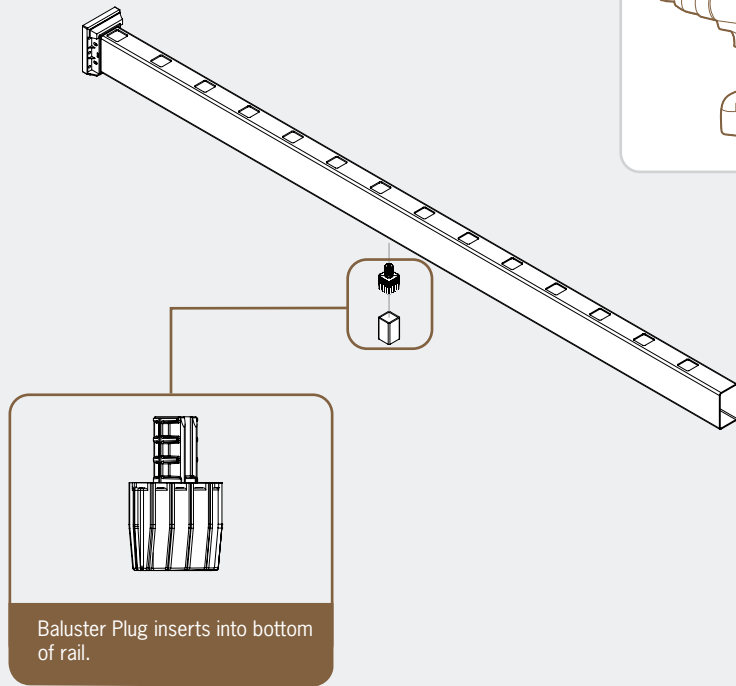
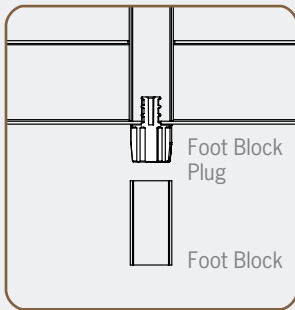

Baluster Plug inserts into bottom of rail.



For sections 3' and under: No Foot Block is necessary

For sections up to 6': Place one Foot Block in the center of the rail

For sections 6' to 8': Space two Foot Blocks at approximately 1/3 intervals on the rail

4

SLIDE BOTTOM RAIL MOUNTING BRACKETS ONTO BOTTOM RAIL ENDS

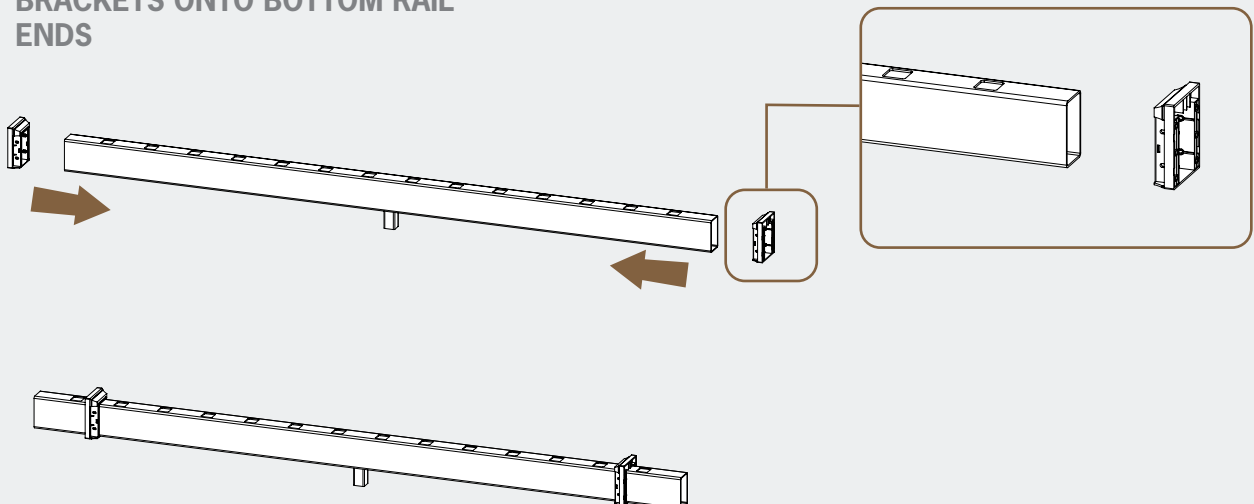

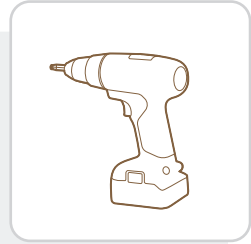

5

*OPTIONAL STEP - INSTALL 45° ADAPTERS

- 45° installation requires an additional Bracket Adapter to achieve the desired angle.
- Install each adapter using 4 (#10 3" T25) screws, then attach standard bracket to adapter as you would to the post.
- Follow the same installation procedure outlined for the Top and Bottom Rails.

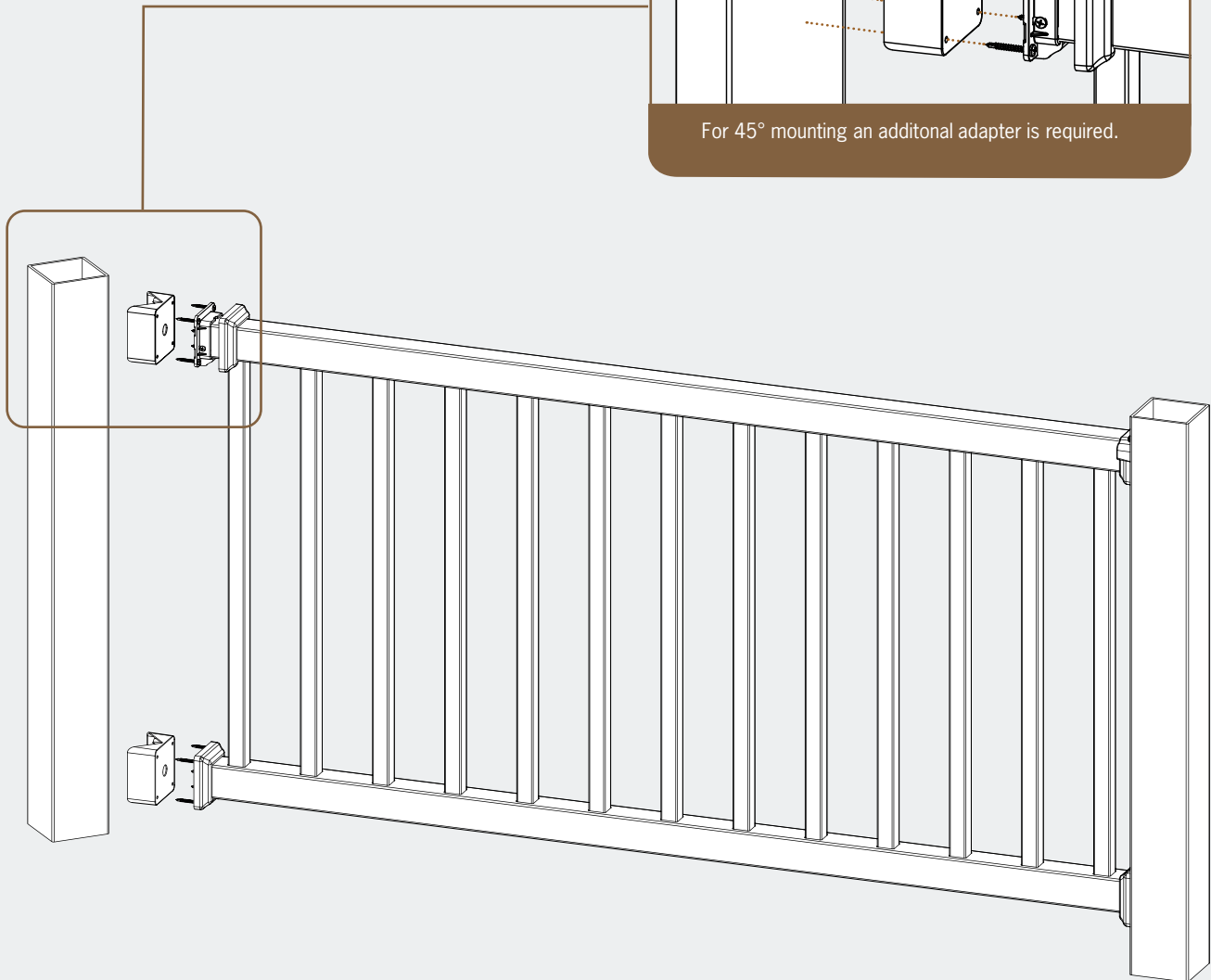
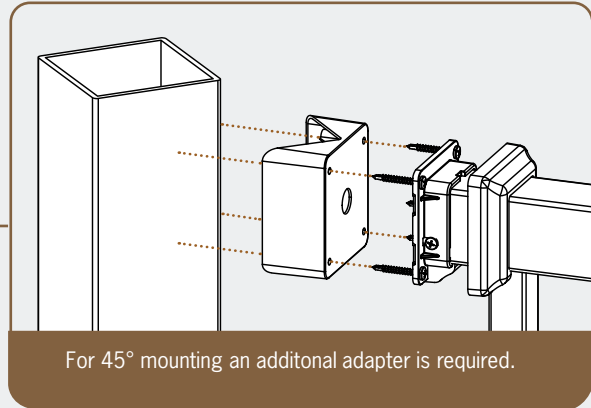

6

INSTALL BOTTOM RAIL

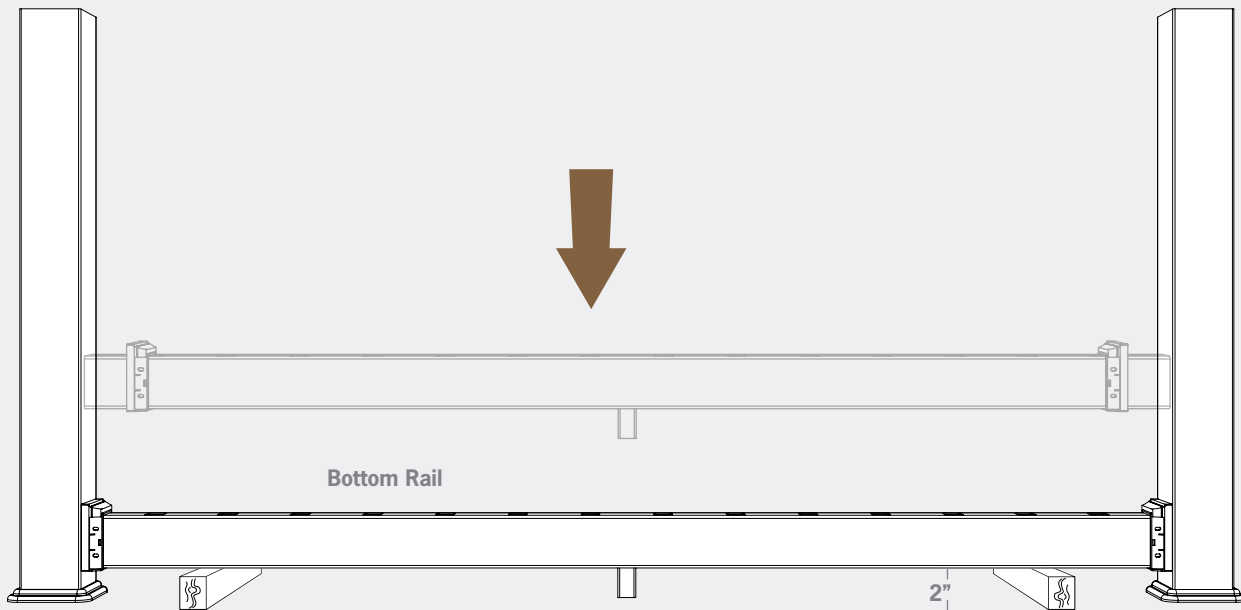
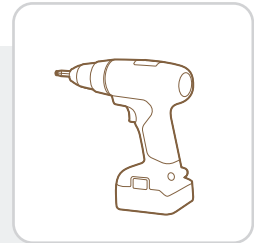

Installation Tips: Use a 2" tall block on each end to help support the rail during installation. Reliance Rail is designed with 2" clearance to achieve stated rail heights.

- Center Bottom Brackets within Post Sleeves.
- Fasten Brackets to post using 4 (#10 1 5/8" T25) screws after pre-drilling with 5/32" drill bit. Install screw at slight angle.
- Fasten Bracket to Bottom Rail using 4 (#10 1" T25) screws after pre-drilling with 5/32" drill bit

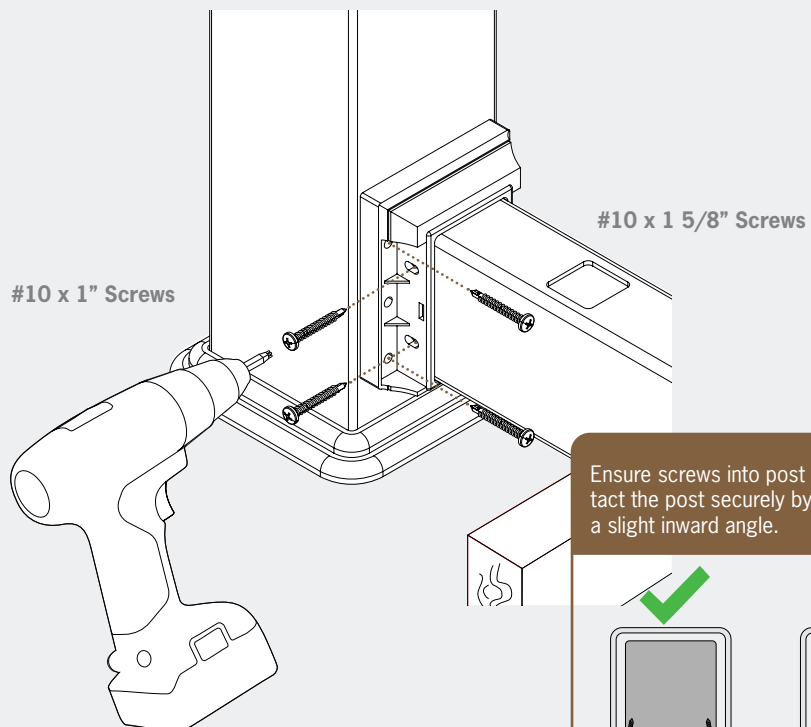

Ensure screws into post sleeve contact the post securely by installing at a slight inward angle.

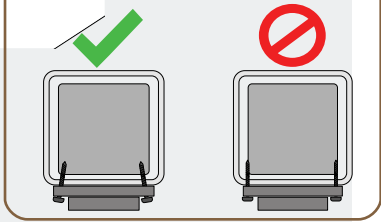

7 INSTALL BALLUSTERS

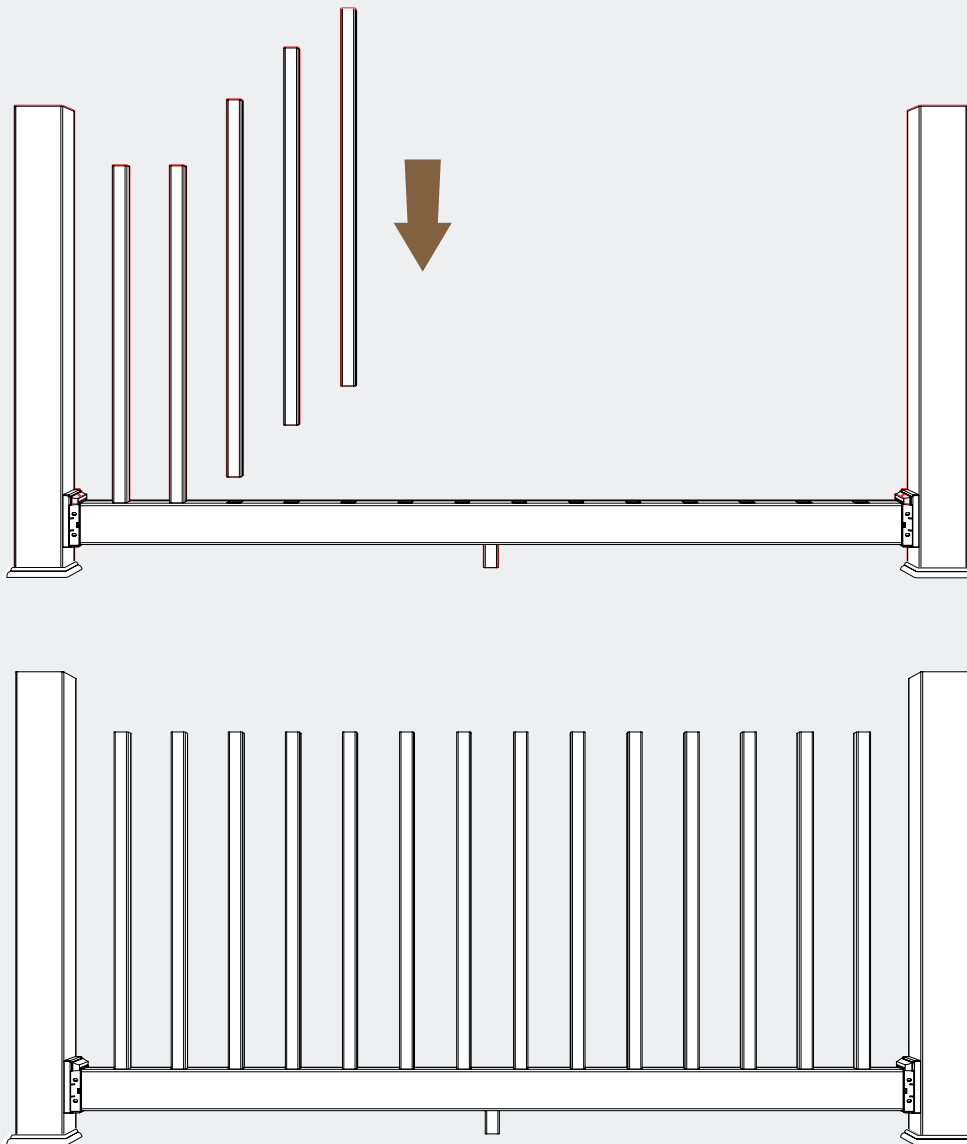

Installation Tips (Straight Section): Find a flat, non-marking work surface. Assemble the balusters to the top and bottom rails with the aluminum reinforcement in place, ensuring that the balusters are properly set within both rails. Using either stretch wrap or a strap, secure the rail assembly towards the ends to keep the section together. Make sure to stay within the rail brackets to avoid interference. Set the assembly on wood blocks, verify that the top rail height is acceptable, center the rail brackets within the post sleeve, and install the brackets into the posts with screws.

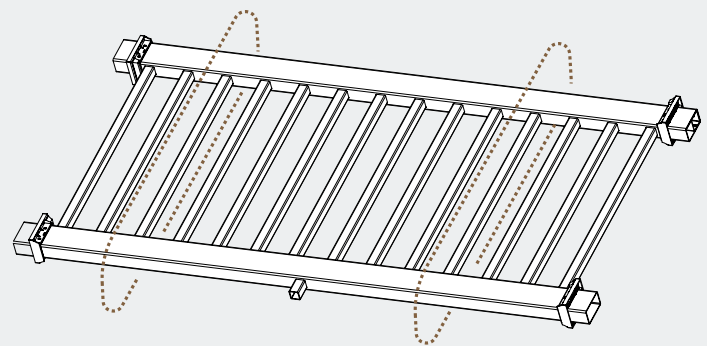

7 SLIDE TOP RAIL MOUNTING BRACKETS ONTO TOP RAIL

- Be sure that Aluminum Stiffener rail is slid into Top Rail at the proper orientation.
- Slide Mounting Brackets on to each side of the the Top Rail
- If installing Drink Rail Mounting Brackets will need to flipped upside down when installing. (See page 16)

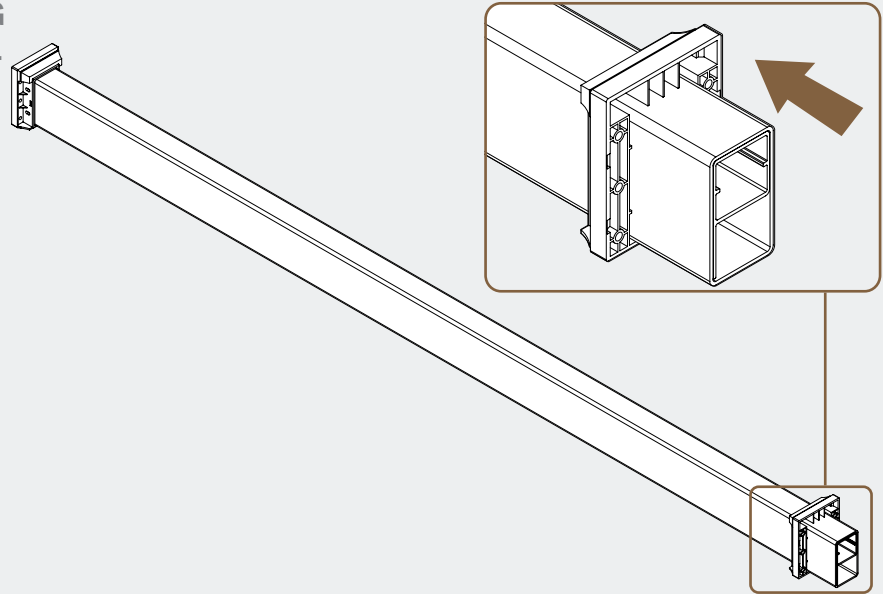

8 INSTALL TOP RAIL AND FASTEN MOUNTING BRACKETS

- Install Top Rail onto the Balusters.
- Ensure the long leg section of the P-shaped Aluminum Stiffener in the Top Rail is facing towards the deck side (see Fig 1).
- Ensure Top Rail is at the required height from deck surface.
- Check that the Balusters are plumb.
- Center Top Brackets within Post Sleeve.
- Fasten Brackets to post using 4 (#10 1 5/8" T25) screws after pre-drilling with 5/32" drill bit.
- Fasten Brackets to Top Rail using 4 (#10 1" T25) screws after pre-drilling with 5/32" drill bit into the Aluminum Stiffener.

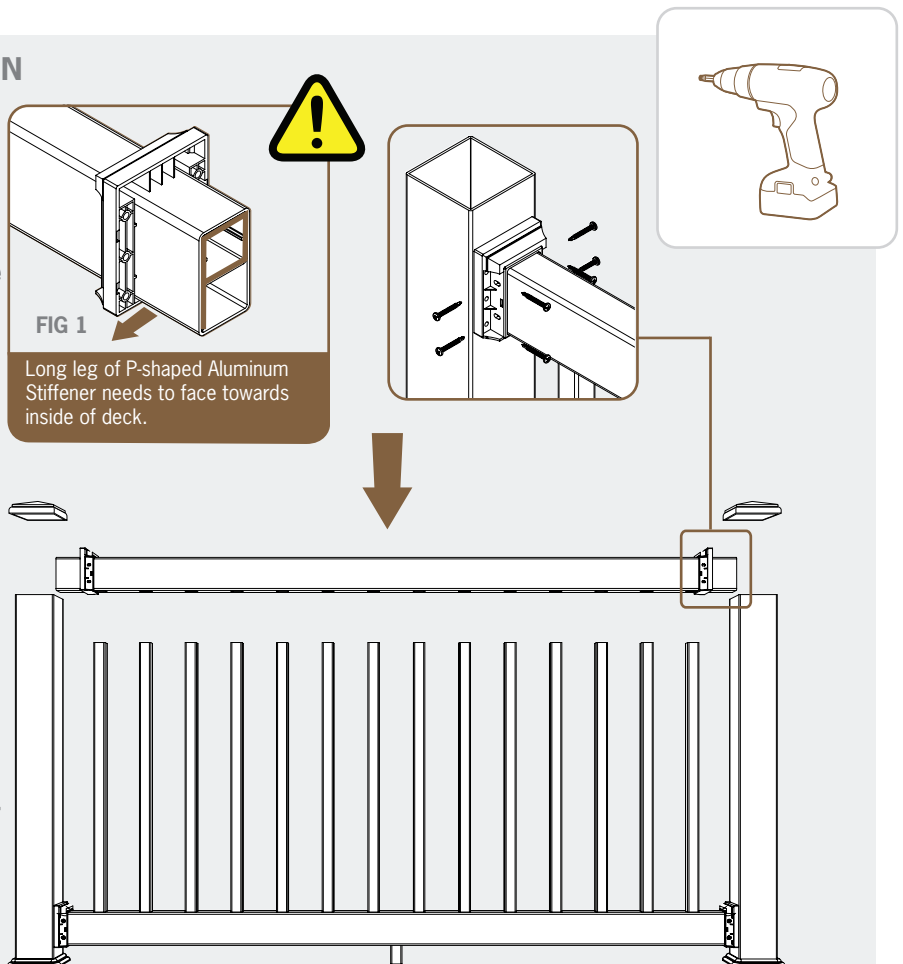

9

INSTALL POST CAPS AND BRACKET COVERS

- Install Post Caps onto Posts.
- Install the Top Rail Bracket Covers.
- Install the Bottom Rail Bracket Covers.
- Bracket Covers snap on to the brackets.

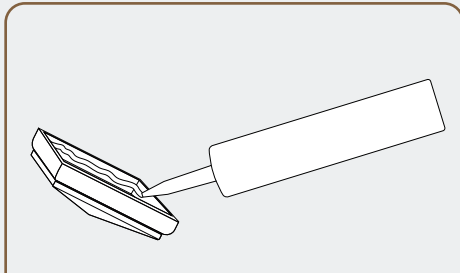

Installation Tips: Apply silicone inside of cap. Do not apply to post and then slide cap on. Do not add silicone to any other parts that it is not intended for.

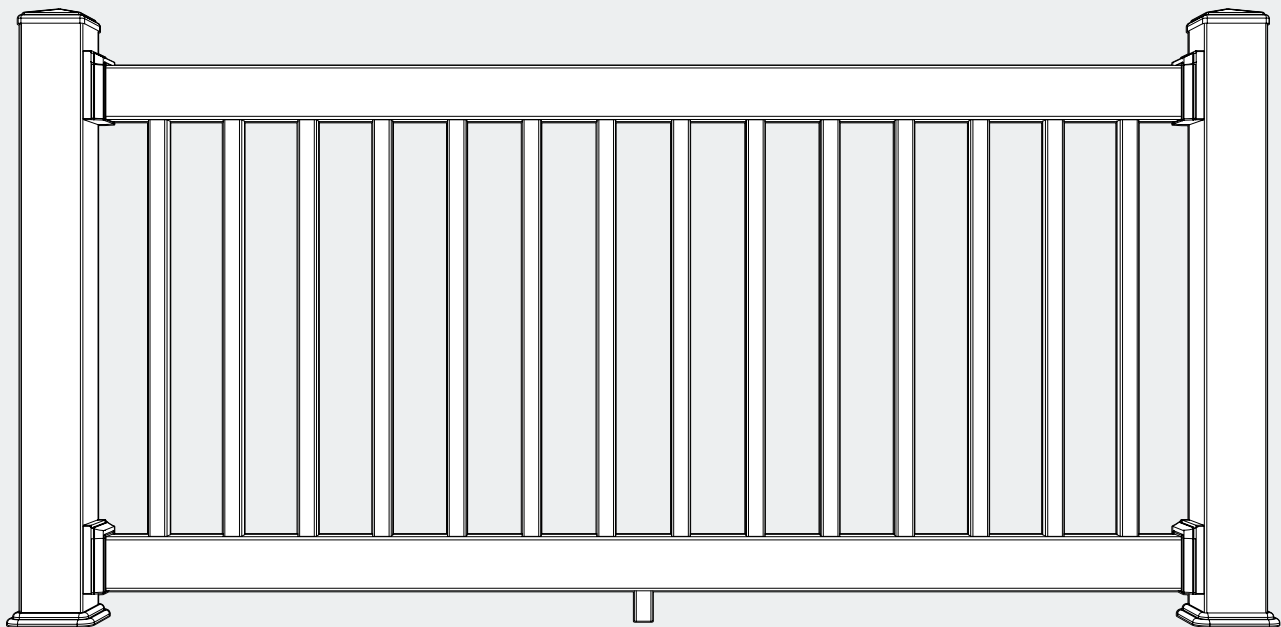
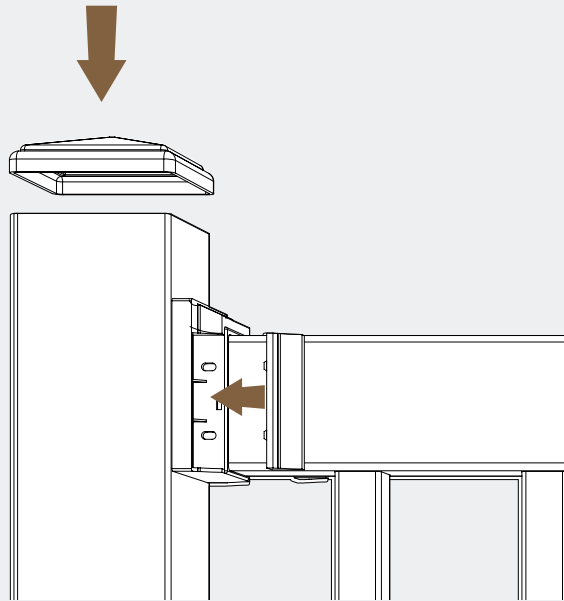



Consult your local building codes for guard and handrail requirements. Core Stair Rail and Brackets are built at a nominal 35° degrees and are designed to accommodate stair angles within the range of 33° to 37°.

1

INSTALL POST SLEEVES AND POST SKIRTS

- Ensure posts are level and plumb.
- Trim Post Sleeves to desired length.
- Slide Post Skirt over Post. Slide Post Sleeve over the post and slide into Post Skirt (do not force). For best fit, shim Post Sleeve between sleeve and support post.

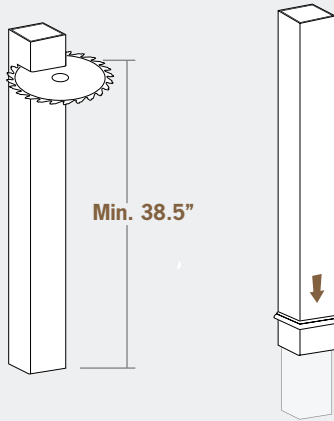

Min height of the post at the top of the stair section is 38.5". The post at the bottom of the stair section should be taller than 42".

IMPORTANT: Be sure to install Post Skirts before railing sections are installed. Installing Post Skirt before Post Sleeve can reduce potential for scratching

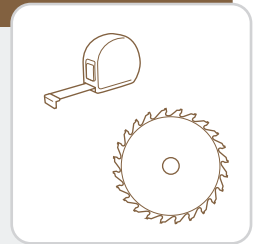

2

CUT TOP AND BOTTOM RAIL

- Lay a piece of wood or plywood (1/4"-3/4" recommended) to set the bottom rail on top of. Ensure that the placement of the bottom rail does not allow a 6" sphere to pass between the bottom rail and the stair tread at any point.
- Ensure the Aluminum Stiffener is in the Top Rail. Cut Top Rail with the Aluminum Stiffener inside at the same time. Blow out any dust and chips after cutting.
- Cut Top and Bottom Rail slightly shorter than inside-to-inside post measurement so it is easier to fit and less likely to scratch. Recommendation: 1/16" - 1/8" short.

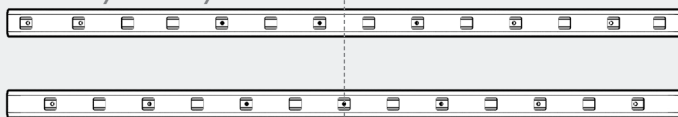

Determine whether the rail will be cut with a hole or Baluster in the center.

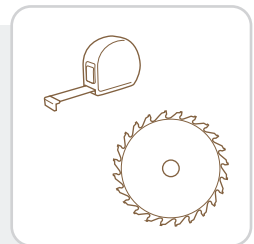
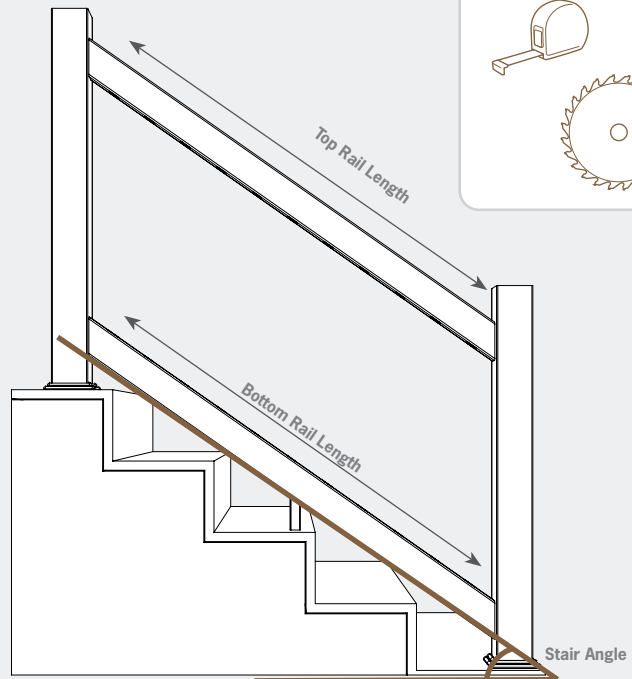

Installation Tip: prior to cutting, use a soft clamp to lock the bottom rail in place against the post and then mark the cut lines.

IMPORTANT: Lay Bottom Rail along stair tread. Position Rail to maximize space between the last cut hole and the Post at each end.



3

MEASURE AND INSTALL FOOT BLOCK(S) ON BOTTOM RAIL

- Position bottom rail 1/4" over stair tread and adjust rail height as needed to ensure that a 6" sphere cannot pass between the stair tread and the Bottom Rail.
- Drill a 1/2" hole into the bottom of the Bottom Rail and insert Foot Block Plug.
- Cut Foot Block(s) to match the angle and height of the rail.
- Attach Foot Block(s) to Foot Block Plug(s).

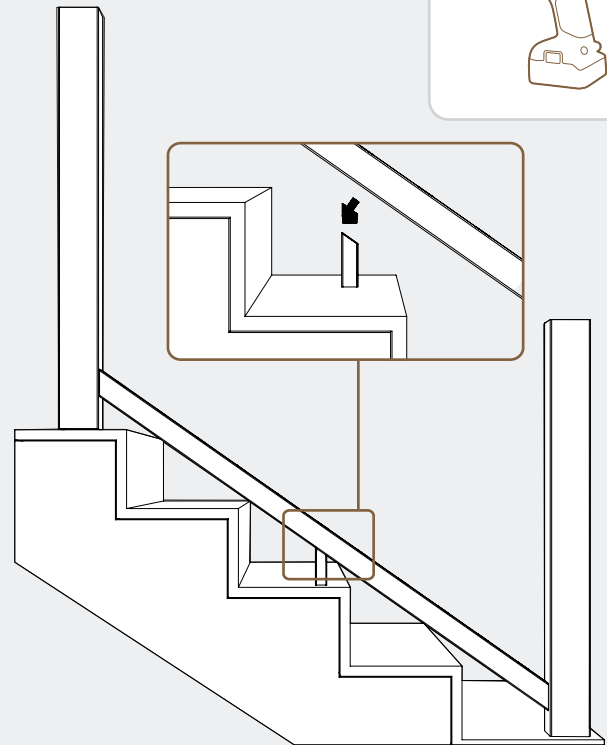

To attach the Foot Block, you must first attach the Foot Block Plug. Drill a 1/2" hole in the bottom of the Bottom Rail and insert plug, then attach Foot Block onto plug.

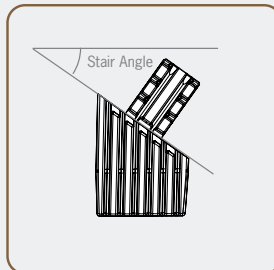

For sections up to 6': Place one Foot Block in the center of the rail

For sections greater than 6': Space two Foot Blocks at approximately 1/3 intervals on the rail

4

SLIDE ON MOUNTING BRACKETS

- After attaching Foot Block, remove Bottom Rail and slide on the Mounting Brackets.
- Reposition Bottom Rail with Mounting Brackets on.

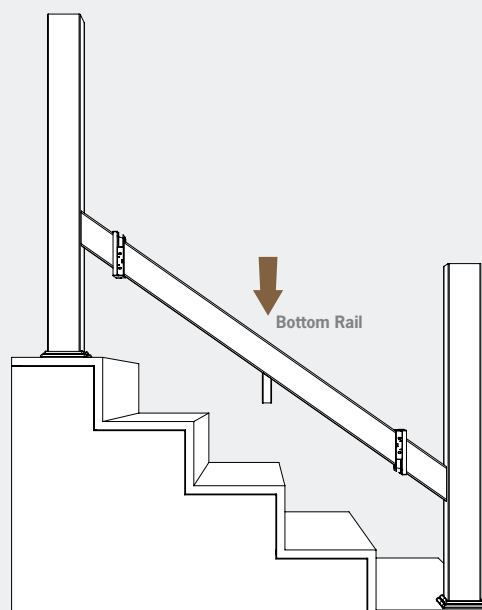

5 INSTALL BOTTOM RAIL

- Position bottom rail 1/4" over stair tread and adjust rail height as needed to ensure that a 6" sphere cannot pass between the stair tread and the Bottom Rail.
- Center Bottom Brackets within Post Sleeves.
- Fasten Brackets to post using (#10 1 5/8" T25) screws after pre-drilling with 5/32" drill bit.
- Fasten Brackets to Bottom Rail using (#10 1" T25) screws, after pre-drilling with 5/32" drill bit into the Aluminum Stiffener.

Note: Be sure to install footblock(s) prior to installing bottom rail.

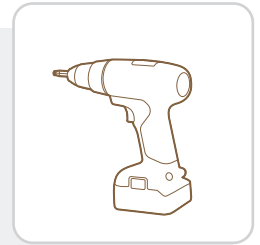
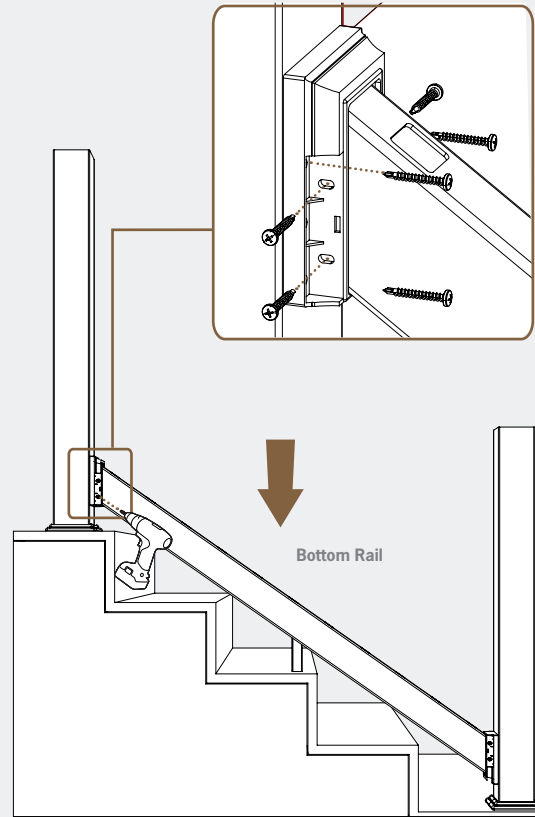

6 INSERT BALUSTERS IN ROUTED HOLES

- Place one baluster in each of the routed holes along the Bottom Rail.

Note: Baluster lengths: 36" system uses 32" balusters, and 42" system uses 38" balusters

Note: pre-assembly of the section can be done after measuring and cutting rails, similar to the process for the level section. (See Page 8).

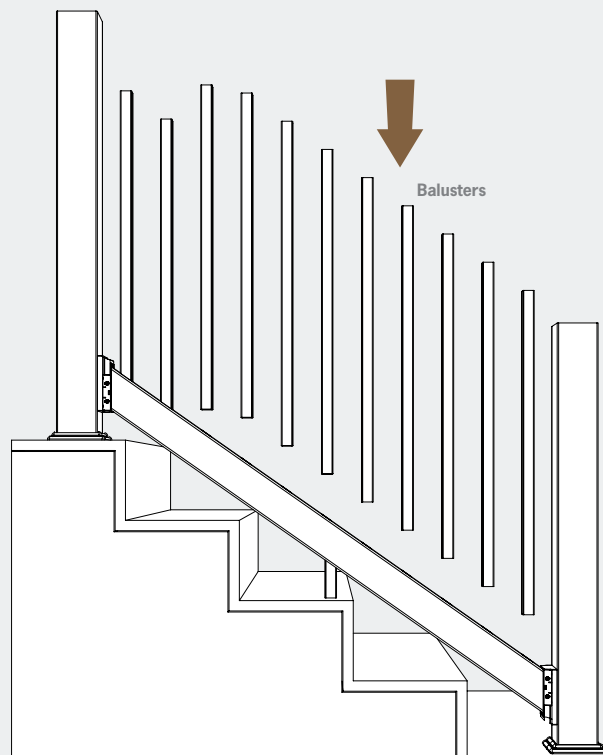

7 INSTALL TOP RAIL AND FASTEN MOUNTING BRACKETS

- Install Top Rail onto the Balusters.
- Ensure The open section of the P-shaped Aluminum Stiffener in the Top Rail is facing towards the deck side (see Fig 1).
- Ensure Top Rail is at the required height from the front nose of the stair tread and check that the Balusters are plumb.
- Center Top Brackets within Post Sleeve and clamp using soft clamp to ensure bracket will not shift upward. Mark hole locations where screws will attach bracket to post. Pre-drill using 5/32" drill bit.
- Fasten Brackets to post using 4 (#10 1 5/8" T25) screws after pre-drilling with 5/32" drill bit. Loosely Install top screws first, followed by bottom screws, then tighten all screws in bracket, being sure to not overdrive screws.
- Fasten Brackets to Top Rail using 2 (#10 1" T25) screws, after pre-drilling with 5/32" drill bit into the Aluminum Stiffener.

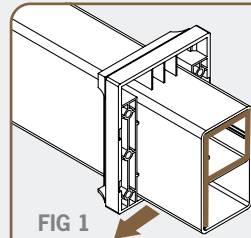
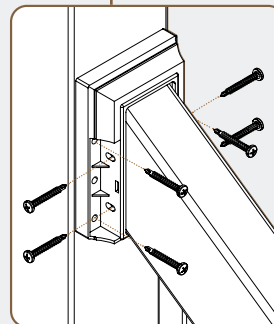
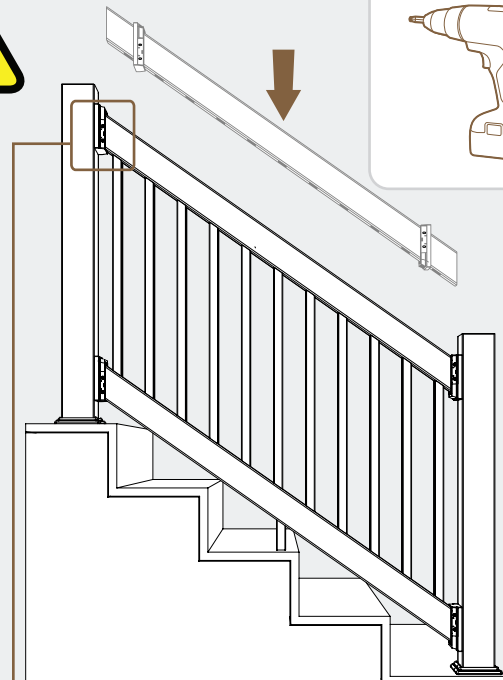

FIG 1

Long leg of P-shaped Aluminum Stiffener needs to face towards inside of deck.



Installation Tip: prior to cutting, use a soft clamp to lock the bottom rail in place against the post and then mark the cut lines.

8 INSTALL BRACKET COVERS

- Bracket Covers snap on to the brackets.

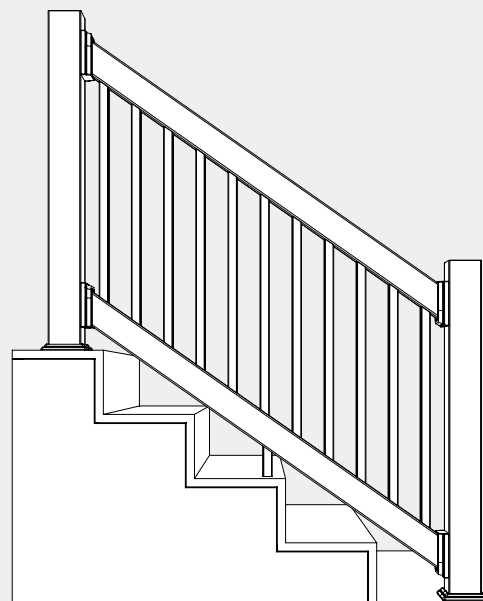
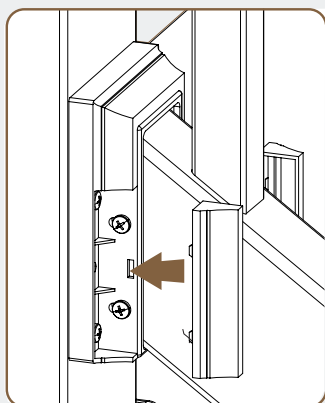

9

ATTACH POST CAPS

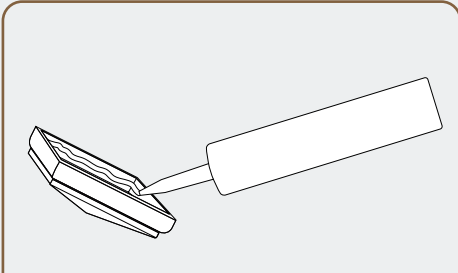

Installation Tips: Apply silicone inside of cap. Do not apply to post and then slide cap on. Do not add silicone to any other parts that it is not intended for.

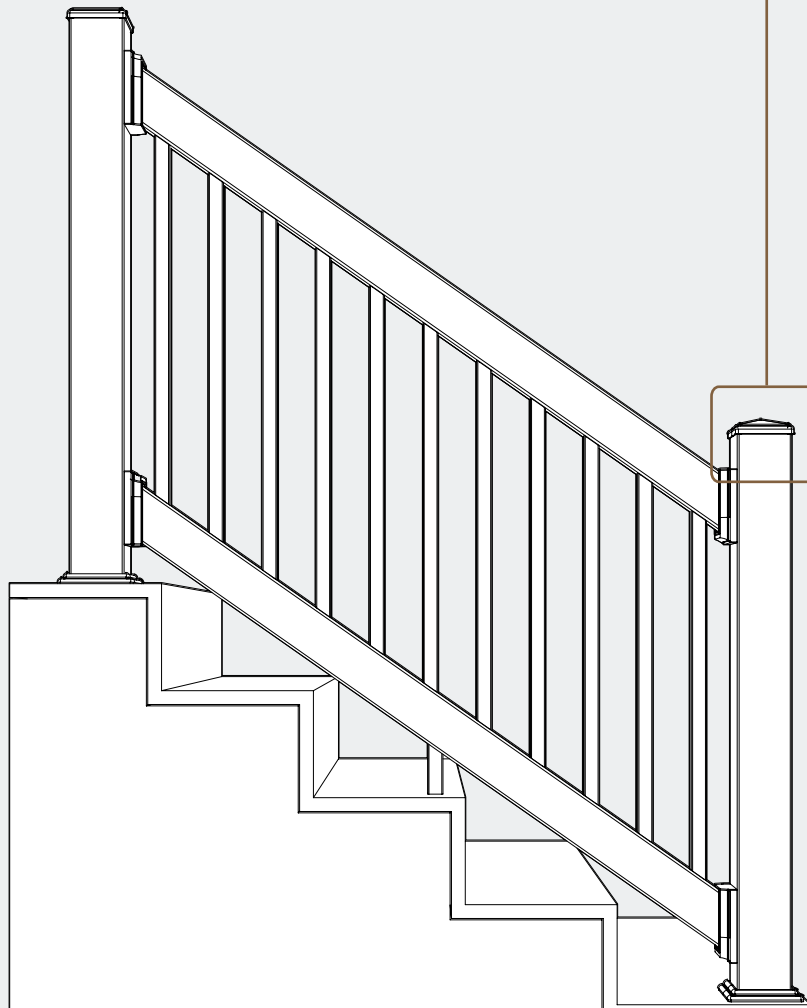
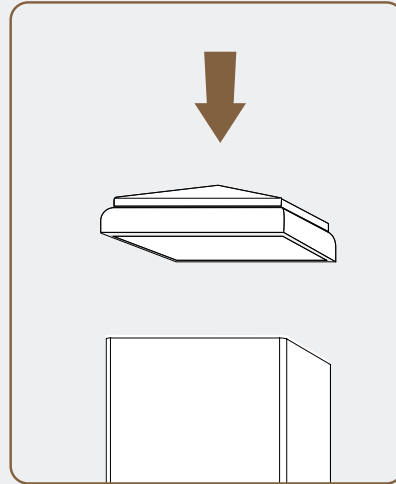

1

INSTALL DRINK RAIL

- Ensure top brackets only are inverted (flipped upside down so the flat side of bracket faces up to create flat surface for Drink Rail) when installing top rail.
- After installing rail section, install the Drink Rail (deck board) by using the Drink Rail Clips included in the Drink Rail Kit to attach the Top Rail to the Drink Rail.
- Install 4 Clips per 6' or 8' section of rail using screws included with Drink Rail Kit. Attach Clips to top rail, then attach Deck Board.

