

INCLUDED PARTS

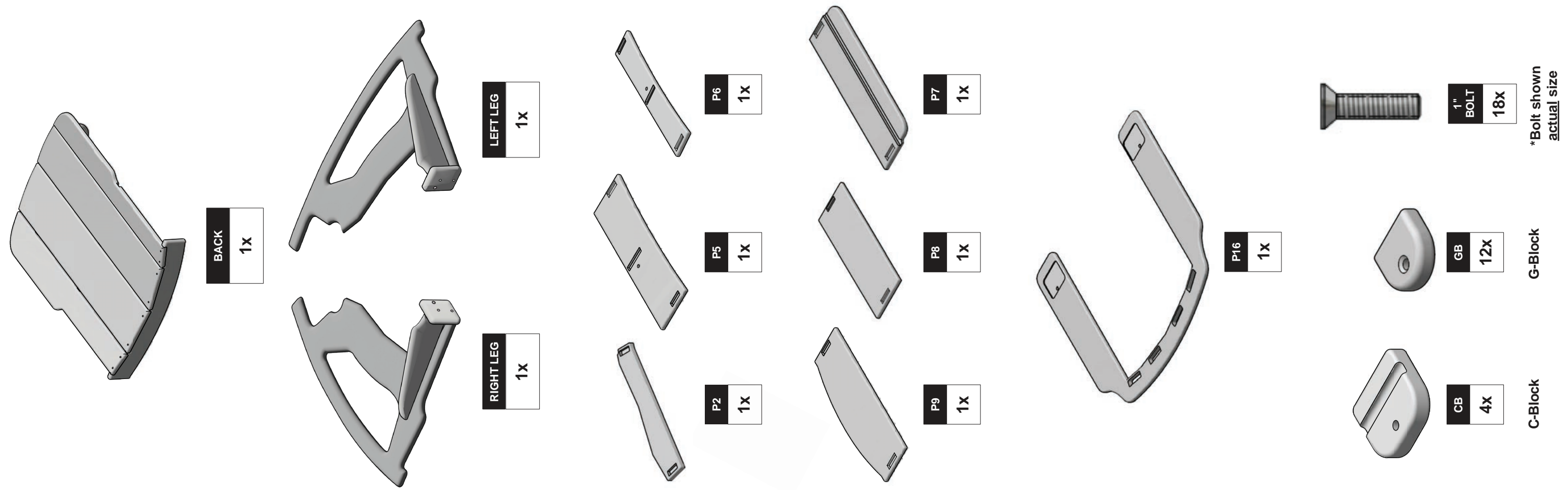

ASSEMBLY TIPS

Please read before beginning assembly and be sure to wear eye protection to avoid injury, particularly if using power tools.

To avoid damaging the furniture, perform the assembly of your new furniture on a clean, soft surface like a blanket, carpet, or the flattened cardboard box the furniture was shipped in. When removing the furniture from the carton, and if using the carton for an assembly surface, please CAREFULLY remove any staples that may have held the shipping carton together. These can scratch you and the furniture and we don't want that to happen. Components should not be unnecessarily forced together! If it seems parts aren't fitting together, it is likely something is misaligned and you should reread the instructions to ensure you are aligning the proper components. The various blocks used in assembly may have a protective film on one side. This surface is hidden after assembly, so the film can remain on the block or it can be removed. We DO NOT recommend using power tools to assemble your new furniture as you can easily cross-thread or over-tighten the bolts and damage the product. If you must use power tools, use only a cordless screw gun/drill with a clutch and with the clutch setting at low/medium torque, being very careful not to over-drive the bolts. All bolts come standard with a thread-locking compound pre-applied to reduce loosening of the bolts over time. Start all bolts by hand and then use the Allen Key/Hex Wrench to tighten until parts are drawn tightly and firmly together.

Please recycle the cardboard box and all paper and plastic packaging materials.

BLOCK & BOLT INSTALLATION

Insert bolts through **countersunk** hole side of blocks as shown below. When done properly, the top of the bolt will sit even or flush with the top surface of the block.

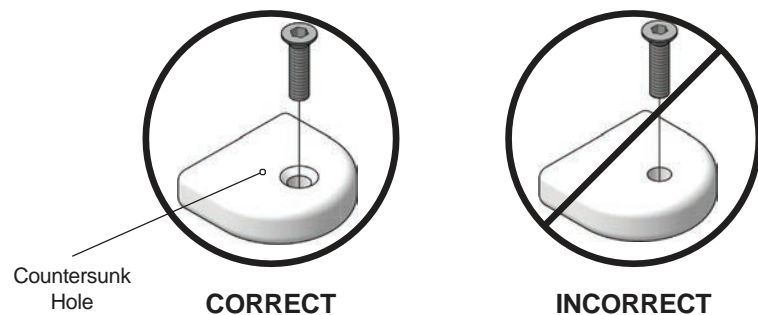

Allen Key/Hex Wrench Install Tool

Included in the carton for use in tightening all bolts.

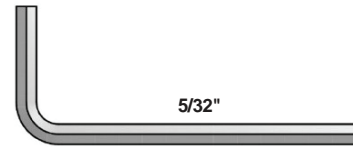

PRODUCT CARE

Your new furniture is a very low-maintenance product. You'll never need to paint or stain it and it can be left outside all year, regardless of the season; however, we are pretty sure your furniture will get a lot of use and will, at some point, need cleaning. We recommend using clean water from a faucet or garden hose and incorporating a soft bristle brush to remove light dirt or spills. Adding a tablespoon or two of your favorite eco-friendly soap to the wash will get everything squeaky clean. Removing mineral deposits from hard water or other tougher cleaning jobs can be done with TimberTech DeckCleaner, which is specially formulated for this type of cleaning.

WARRANTY

TimberTech is known for making beautiful, high-quality outdoor living products that last, and our Invite Collection of Outdoor Furniture is no exception. We want you to be happy that you chose our furniture and satisfied with your purchase, and we back that up with a comprehensive warranty. Please see the TimberTech + Loll Invite Collection Warranty for complete details.

PRODUCT DAMAGED IN SHIPMENT

Sometimes accidents happen. Please inspect your furniture when you receive it to make sure that it has not been damaged during shipping. If damage has occurred, please take digital pictures of the damaged furniture and the box it was shipped in, and call Customer Service using our toll free number: 877-275-2935. The damage will be assessed and you will be contacted with a solution to the problem. If there is any damage, please save all of your packaging material in case a return is necessary.

We want you to love your new furniture.

Reach out if you need assistance.
877-275-2935
1330 W Fulton Market, Suite 350
Chicago, IL 60607



TimberTech®



ASSEMBLY INSTRUCTIONS & PRODUCT INFO: LOUNGE ROCKER

*Bolt shown actual size

G-Block

C-Block

1

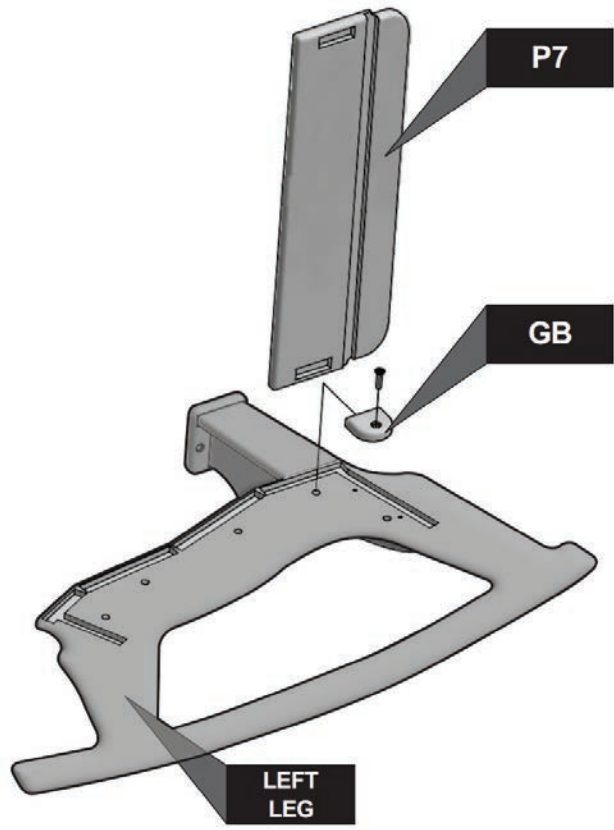

1" BOLT
1x

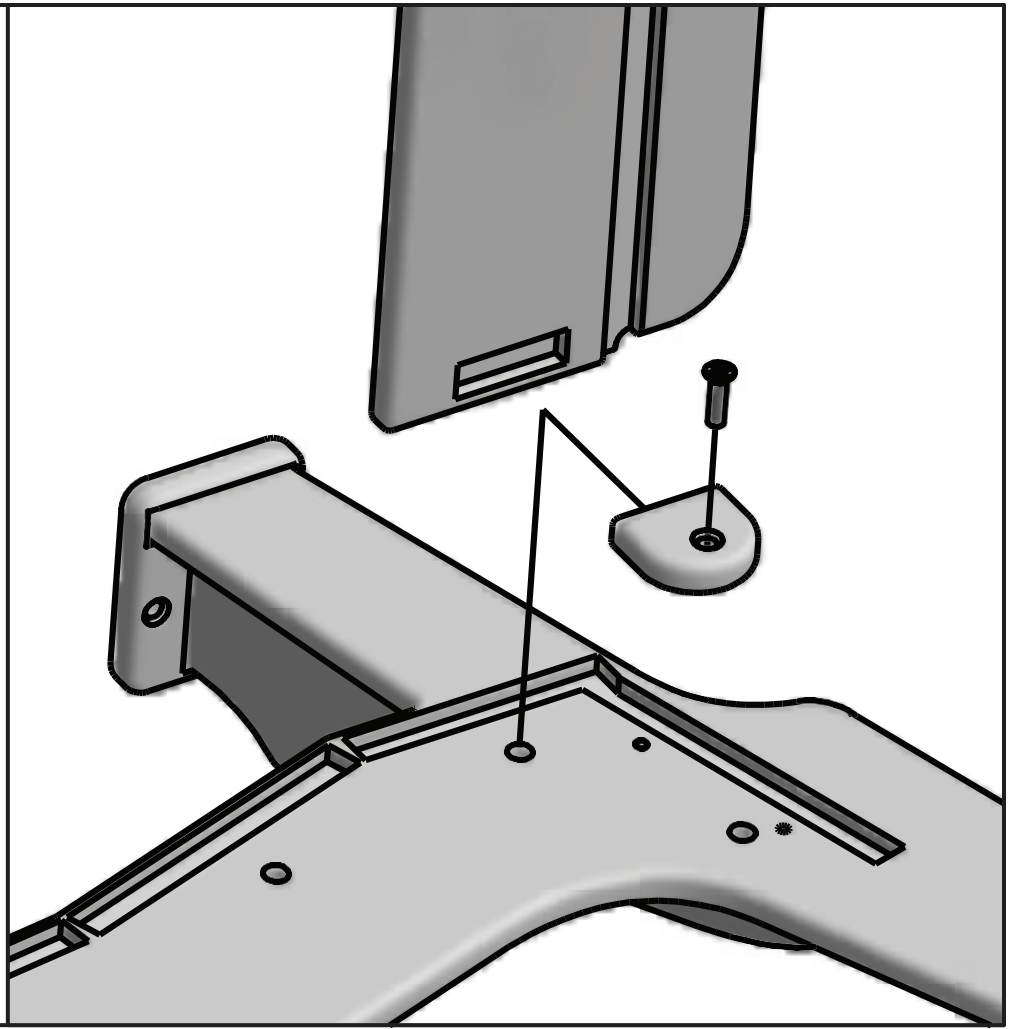

2

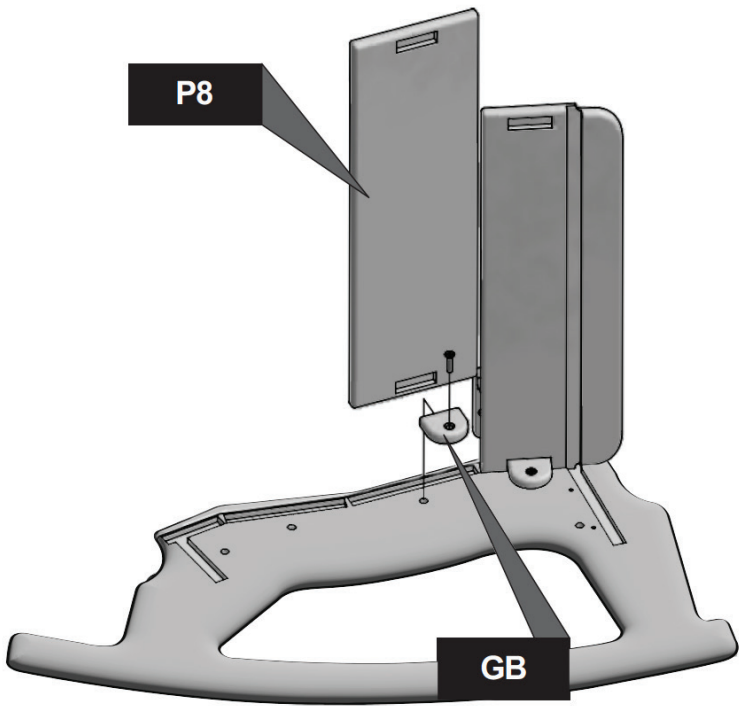

1" BOLT
1x

3

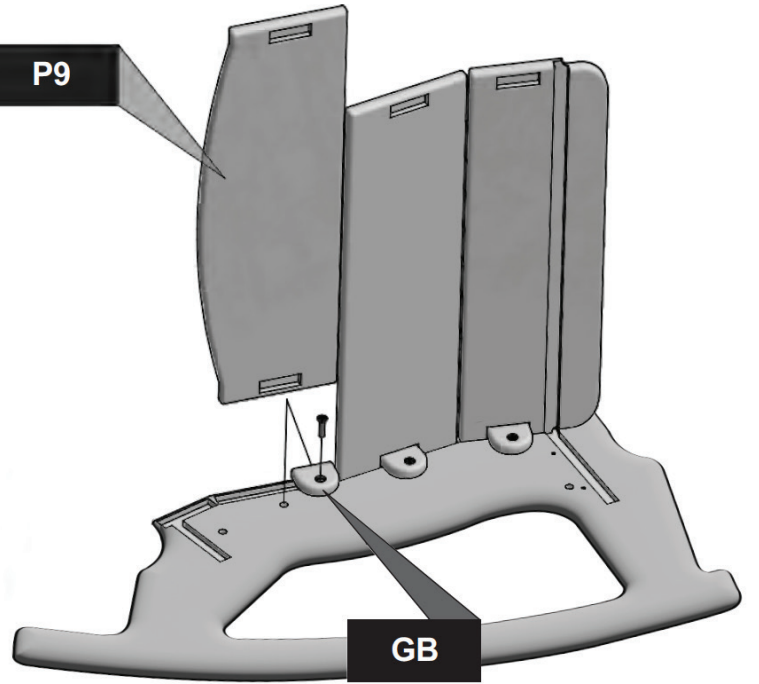

1" BOLT
1x

4

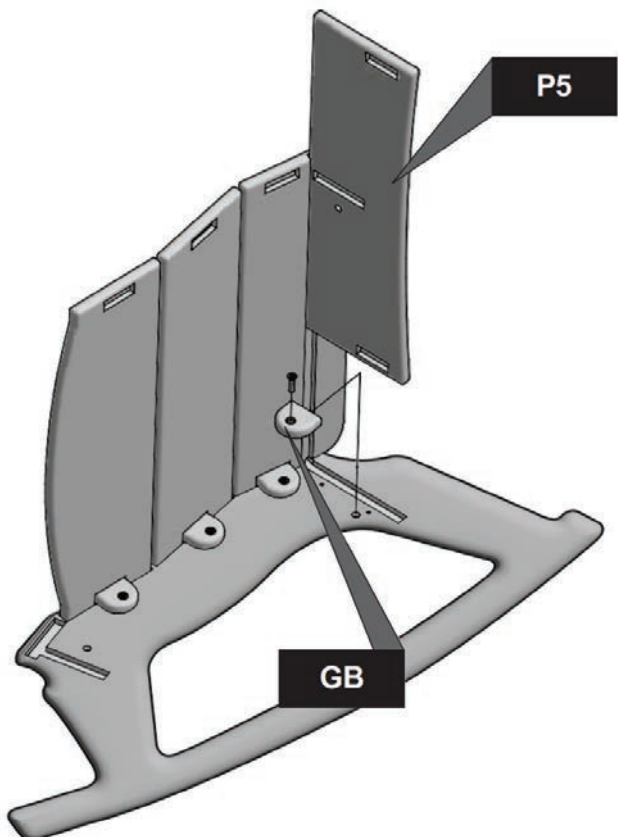

1" BOLT
1x

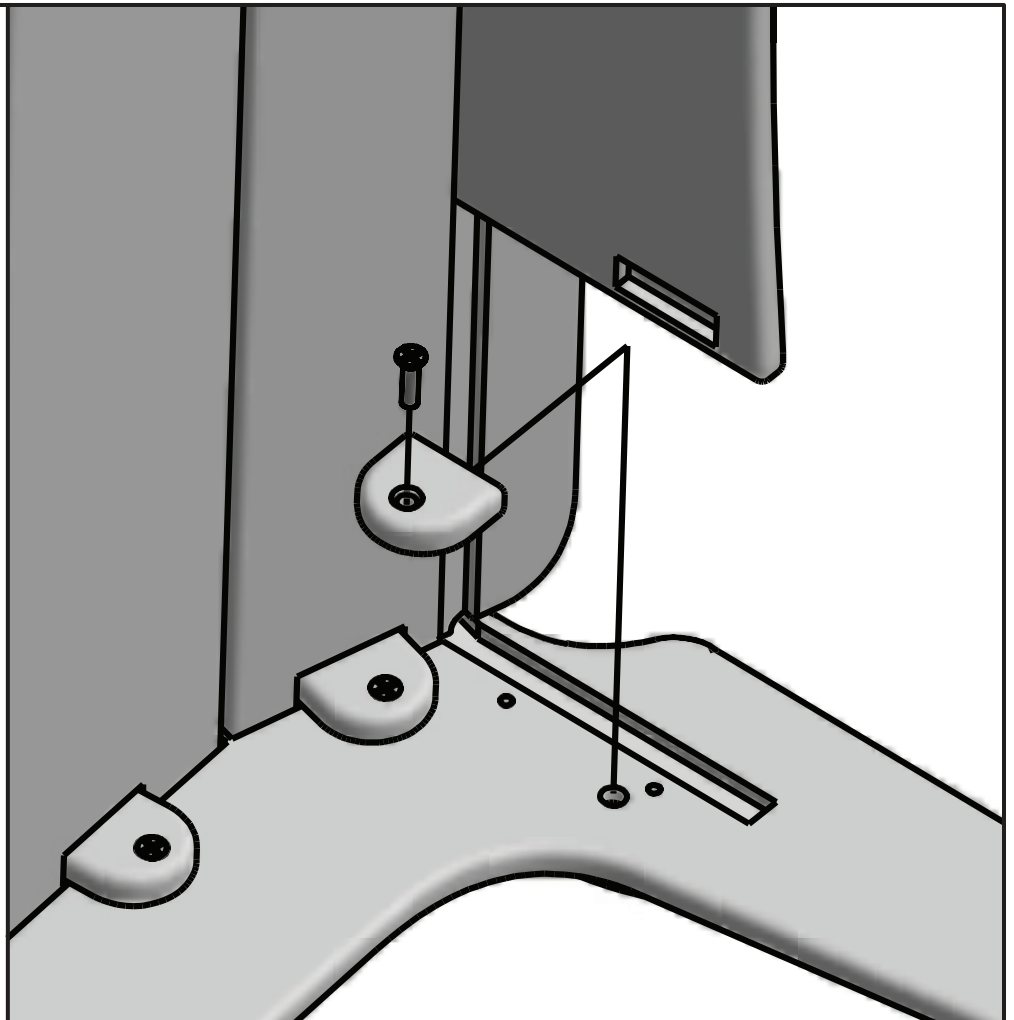

5

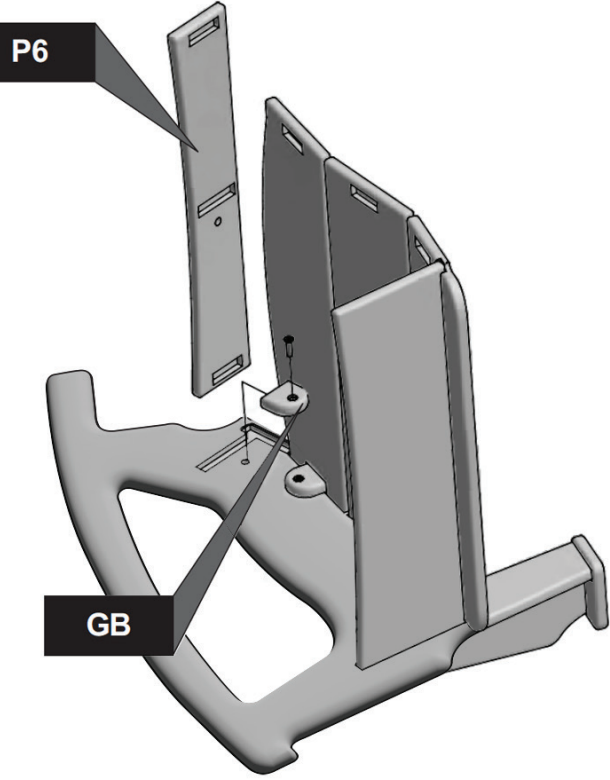

1"
BOLT
1x

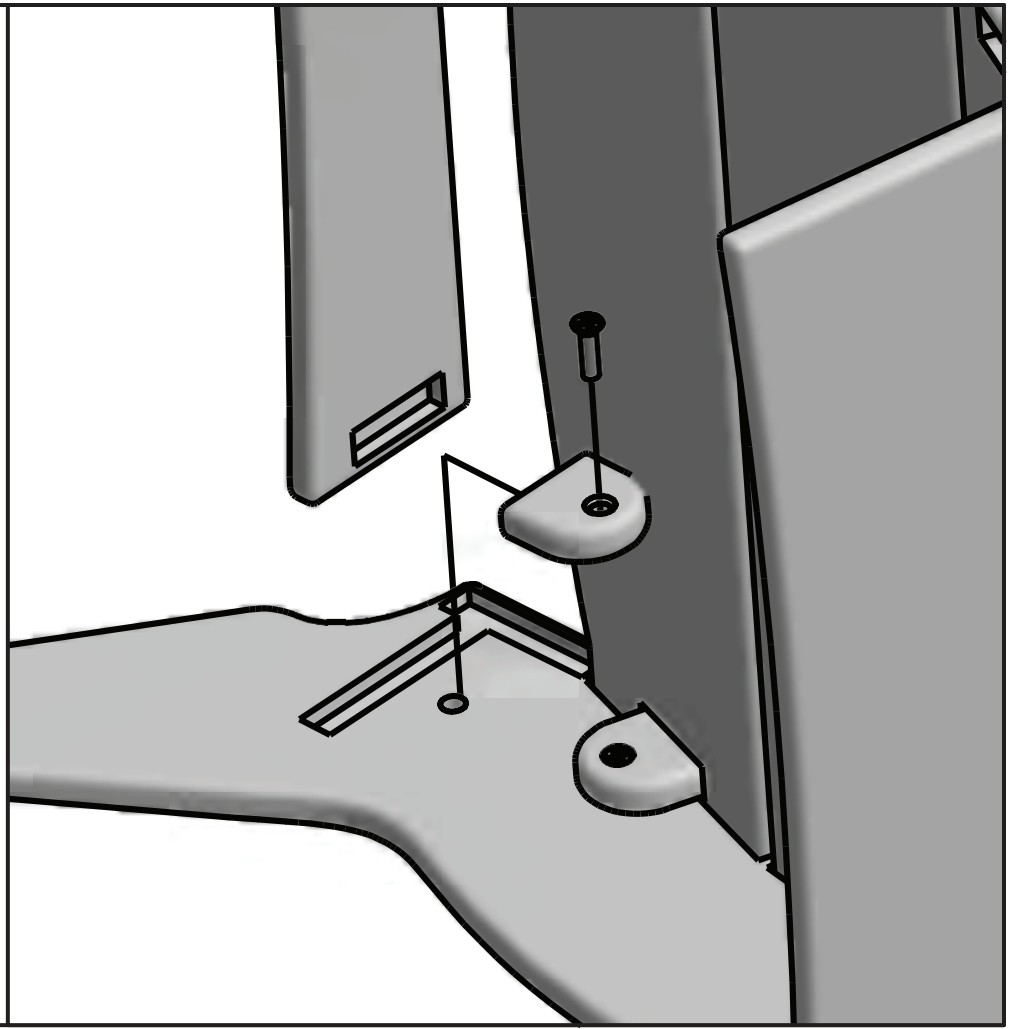

6

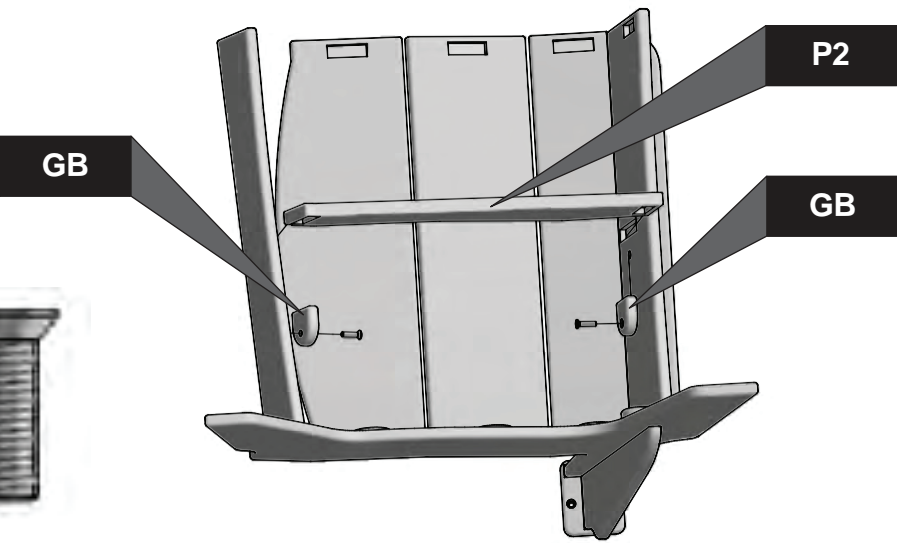

1"
BOLT
2x

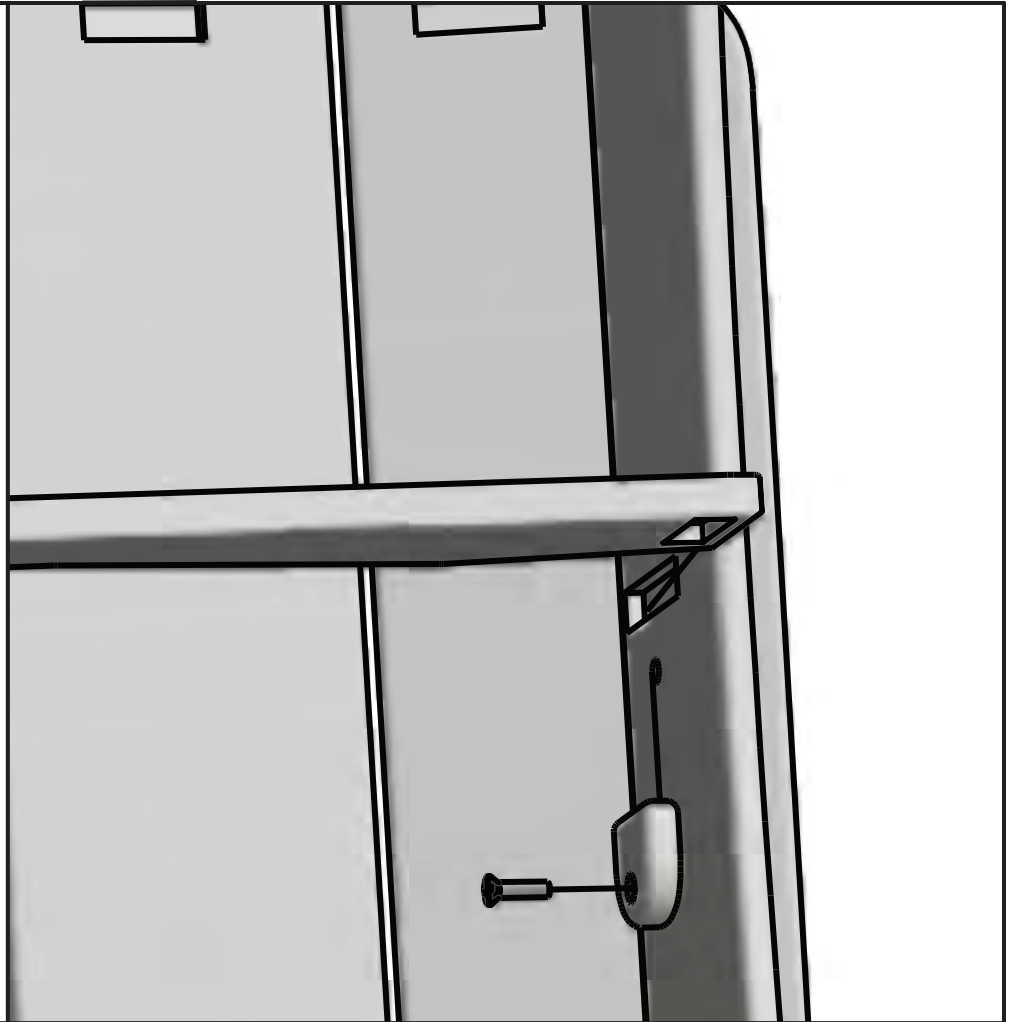

7

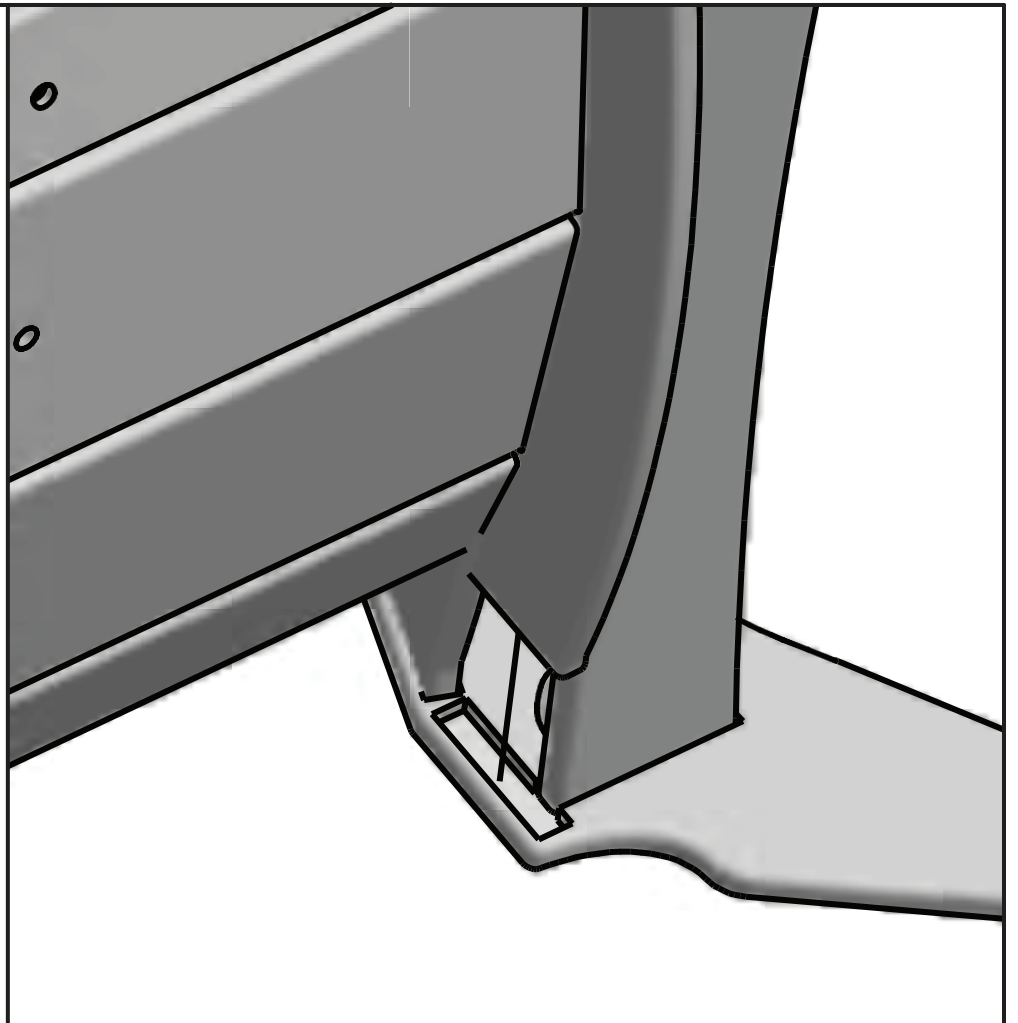
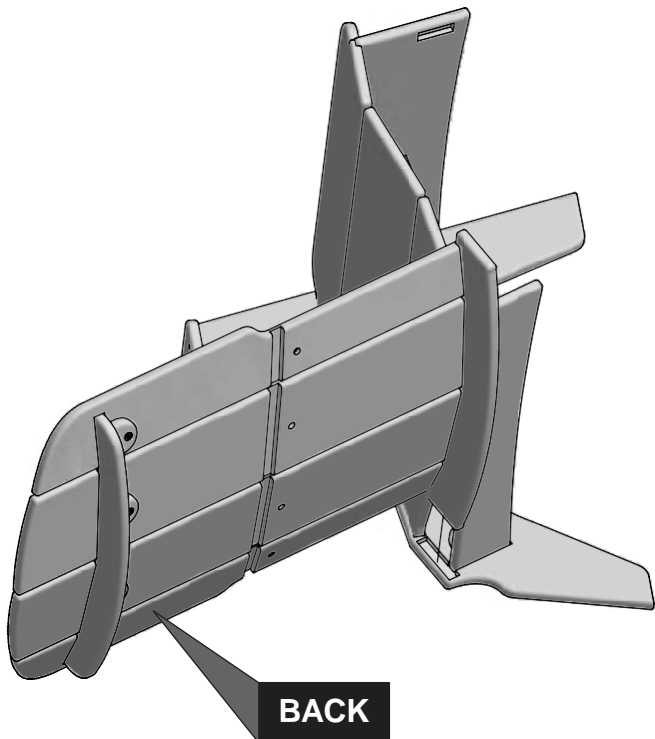

8

RIGHT LEG

GB

5x

1" BOLT

5x

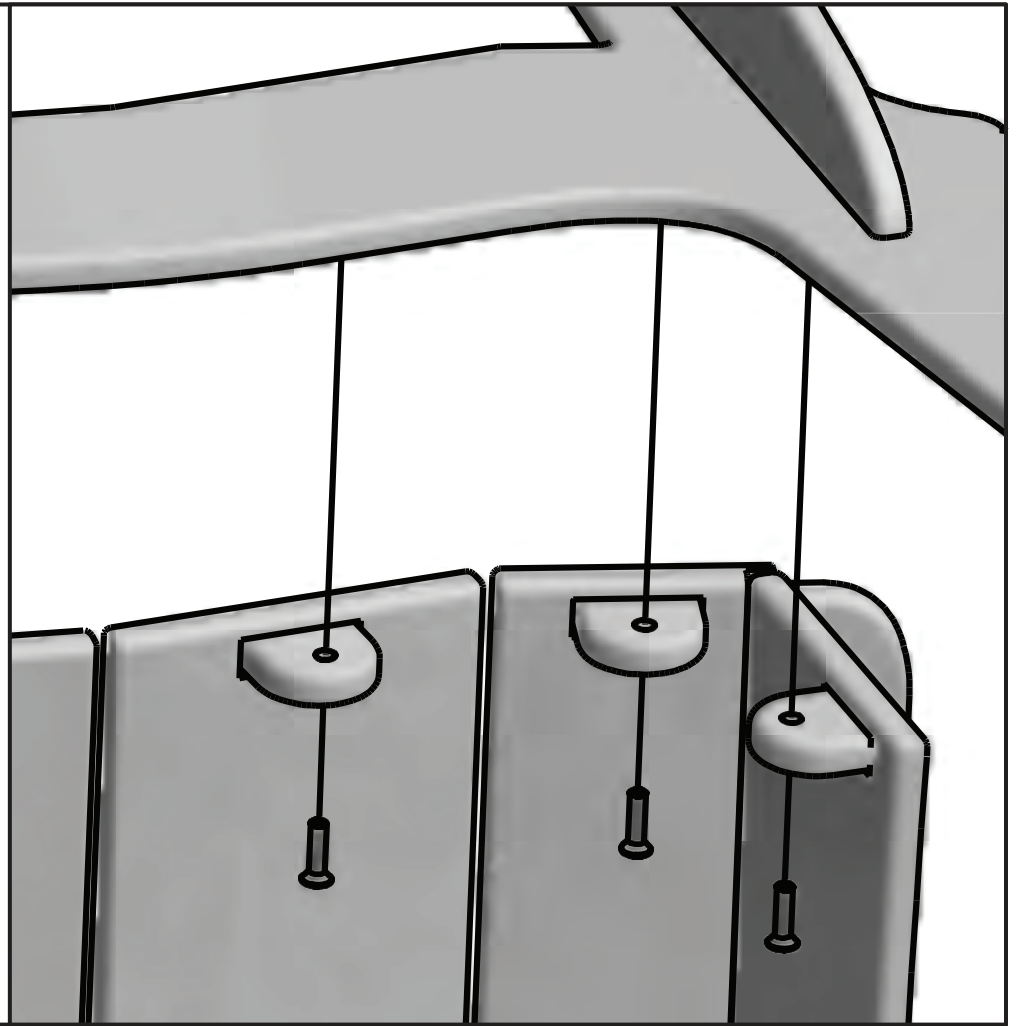

9

P16

1" BOLT

2x

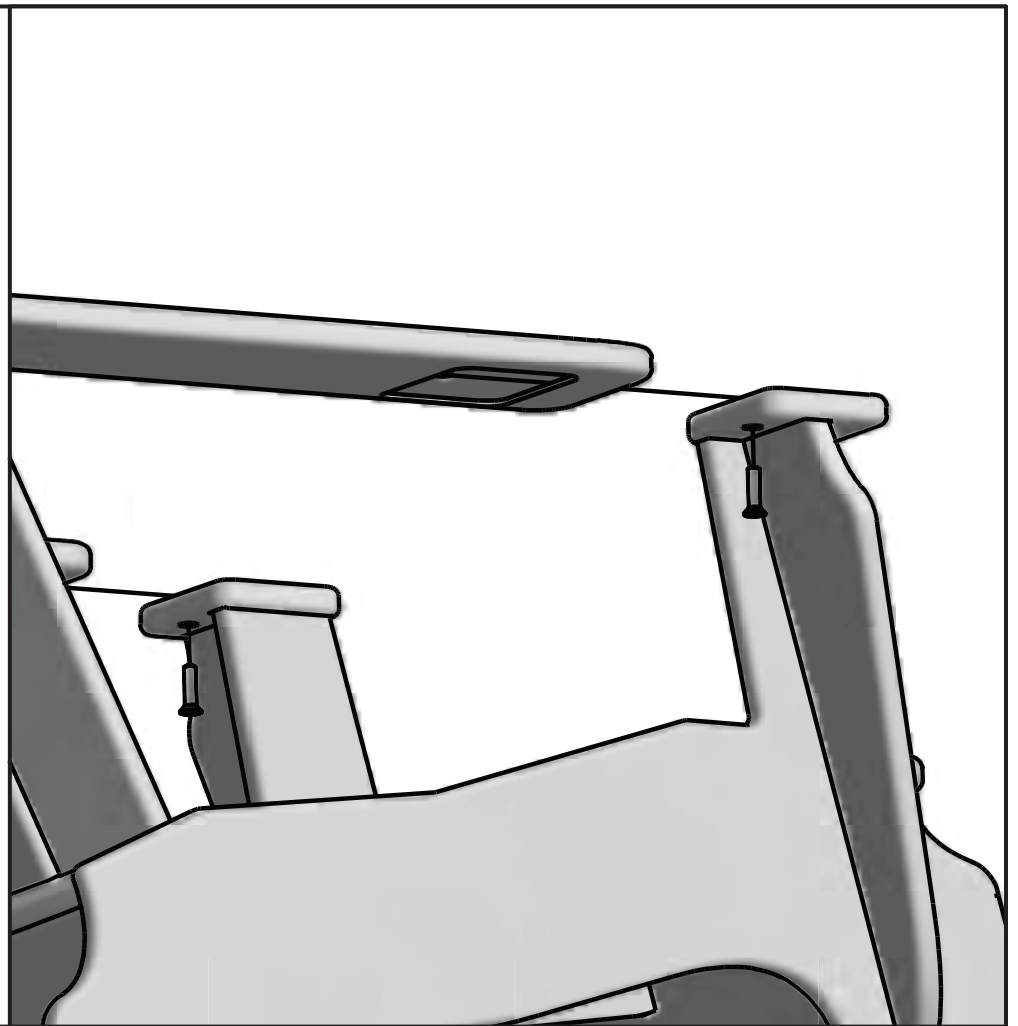

10

CB

4x

1" BOLT

4x

